

# FCM2630-E00 - Pre-calibrated Module for Refrigerant Gases R-32

### Features:

- \* Factory calibrated
- \* Temperature compensation circuit
- \* Resistant to interference gases
- \* Open collector output (monitoring/alarm/malfunction output)
- \* Meets IEC60335-2-40 and JRA4068 requirements

### Applications:

- \* Refrigerant gas leak detection in air conditioning/refrigeration systems

FCM2630-E00\* is an embedded type module using the semiconductor gas sensor TGS2630 which is optimized to detect A2L refrigerant gas R-32.

This module enables users to easily build a reliable gas leakage detection system by eliminating electronic circuit design for temperature compensation and the calibration process. In addition, a connector allows easy replacement of the gas sensor module for periodic maintenance.

The TGS2630 gas sensor has a built-in filter to reduce the influence of alcohol and other interference gases, resulting in high selectivity to R-32. For more detailed information on the gas sensor, including sensitivity characteristics, see *TGS2630 Product Information*.

FCM2630-E00 is capable of satisfying the IEC60335-2-40 Edition 6.0 Annex LL and the JRA4068:2021 (Performance 3) standards. The applicable standards are both limited to refrigerant gas type: R-32.

\* FCM Series is the model name of refrigerant gas sensor modules supplied by Figaro Engineering Inc.

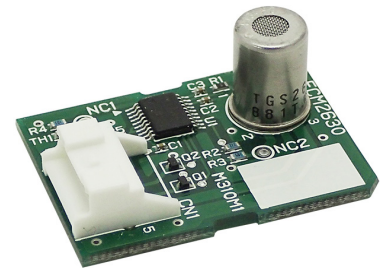

### Circuit Diagram

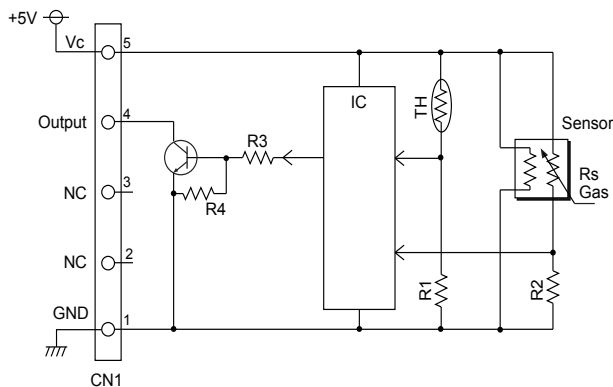

### Pin Connections

Pin No.	Name	Description
1	GND	Common ground
2	NC	No connection
3	NC	No connection
4	Output	Monitoring/alarm/malfunction output
5	Vc	Circuit voltage

Connector model: S05B-PASK-2 (made by JST)

Recommended receptacle for connector: PAP-05V-S (made by JST)

### Specifications

Model No.	FCM2630-E00	
Gas sensor	TGS2630	
Target gases	Refrigerant gas R-32	
Circuit voltage	Vc	5.0±0.2V DC
Output signals	NPN Open collector (See table below for details.)	
Alarm set point	5000ppm	
Initial alarm accuracy	R-32: 2800 ~ 7000ppm	
Response time	within 30 seconds at 36000ppm R-32	
Warm-up time	60 seconds after power ON If previous operation mode was in Alarm state when power was turned off, the Alarm state will be resumed before completion of the initial stabilization period.	
Operating conditions	-25 ~ 60°C, 20 ~ 95%RH(avoid condensation)	
Current consumption	approx. 60mA (Inrush current: 100mA)	
Power consumption	approx. 0.3W	
Dimensions	25 × 34 × 16mm	
Weight	approx. 5g	

### Output Signals

Operation State	Output
Initial	H: 75msec./L: 300msec.
	Alarm decision and malfunction decision inactive for 60sec. after power on
Monitoring	H: 75msec./L: 300msec.
Alarm	H: 225msec./L: 150msec.
	Alarm state will not change to another operation state.
Malfunction	H: 300msec./L: 75msec.
	Malfunction state will not change to Initial state or Monitoring state. Since gas detection mode continues while in Malfunction state, Malfunction state will change to Alarm state if sensor response reaches or exceeds the alarm set point.

**Operation state priority:** ① Alarm ② Malfunction ③ Initial ④ Monitoring  
(The output signals should be connected to external pull-up resistances.)

#### NOTE 1:

Once a gas sensor module is exposed to 10,000ppm or more of R-32, Alarm state is kept thereafter. Do not apply high concentration test gas equivalent to 10,000ppm or more of R-32 while evaluating gas sensor modules. Replace a gas sensor module if it is exposed to a high concentration R-32 gas because its normal performance may be no longer maintained.

#### NOTE 2:

If the internal temperature near the gas sensor module becomes higher than the external ambient temperature by 10°C or more due to heat generated by electronic components in a device into which this gas sensor module is incorporated, the set alarm threshold may drift. Please consult with Figaro if there is difficulty in designing a device so as to keep the temperature rise inside the device within 10°C.

### Structure and Dimensions

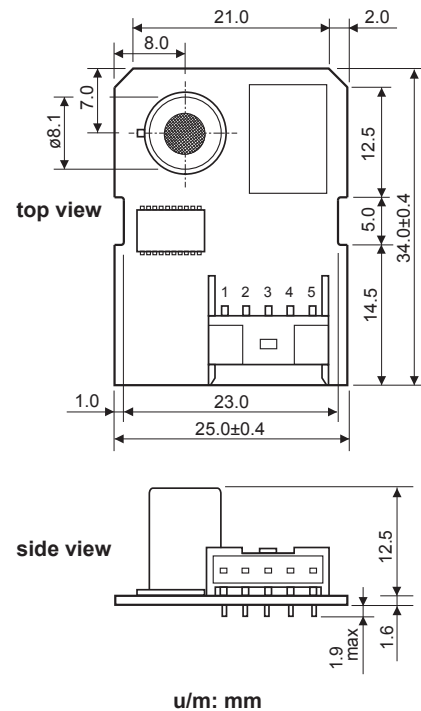

All sensor characteristics shown in this brochure represent typical characteristics. Actual characteristics vary from sensor to sensor. The only characteristics warranted are those in the Specification table above.

Before purchasing this product, please read the Warranty Statements shown in our webpage by scanning this QR code.



[https://www.figaro.co.jp/en/pdf/Limited\\_Warranty\\_en.pdf](https://www.figaro.co.jp/en/pdf/Limited_Warranty_en.pdf)

**FIGARO ENGINEERING INC.**  
1-5-11 Senba-nishi  
Mino, Osaka 562-8505 JAPAN  
Phone: (81)-727-28-2045  
URL: [www.figaro.co.jp/en/](http://www.figaro.co.jp/en/)