

# TGS 2611-E00 - for the detection of Methane

### Features:

- \* High selectivity to methane
- \* Low power consumption
- \* Long life and low cost
- \* Uses simple electrical circuit

### Applications:

- \* Domestic gas alarms
- \* Portable gas detectors
- \* Gas leak detector for gas appliances

**TGS2611-E00** is a semiconductor type gas sensor which combines very high sensitivity to methane gas with low power consumption and long life. Due to miniaturization of its sensing chip, TGS2611-E00 requires a heater current of only 56mA and the device is housed in a standard TO-5 package.

TGS2611-E00 uses filter material in its housing which eliminates the influence of interference gases such as alcohol, resulting in highly selective response to methane gas. This feature makes the sensor ideal for residential gas leakage detectors which require durability and resistance against interference gas.

The TGS2611-E00 is able to satisfy the requirements of performance standards such as UL1484 and EN50194.



The figure below represents typical sensitivity characteristics, all data having been gathered at standard test conditions (see reverse side of this sheet). The Y-axis is indicated as sensor resistance ratio ( $R_s/R_o$ ) which is defined as follows:

- $R_s$  = Sensor resistance at various concentrations
- $R_o$  = Sensor resistance in 5000ppm of methane

### Sensitivity Characteristics:

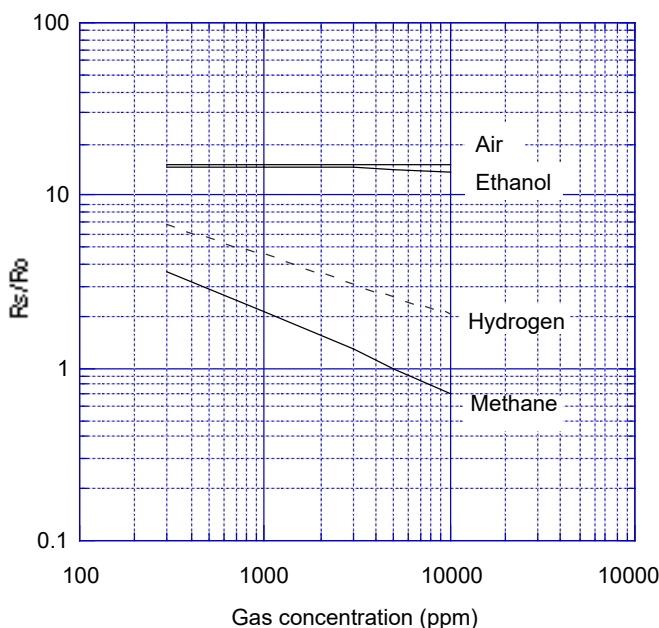

The figure below represents typical temperature and humidity dependency characteristics. The Y-axis is indicated as sensor resistance ratio ( $R_s/R_o$ ), defined as follows:

- $R_s$  = Sensor resistance in 5000ppm of methane at various temp/humidities
- $R_o$  = Sensor resistance in 5000ppm of methane at 20°C/65%RH

### Temperature and Humidity Dependency:

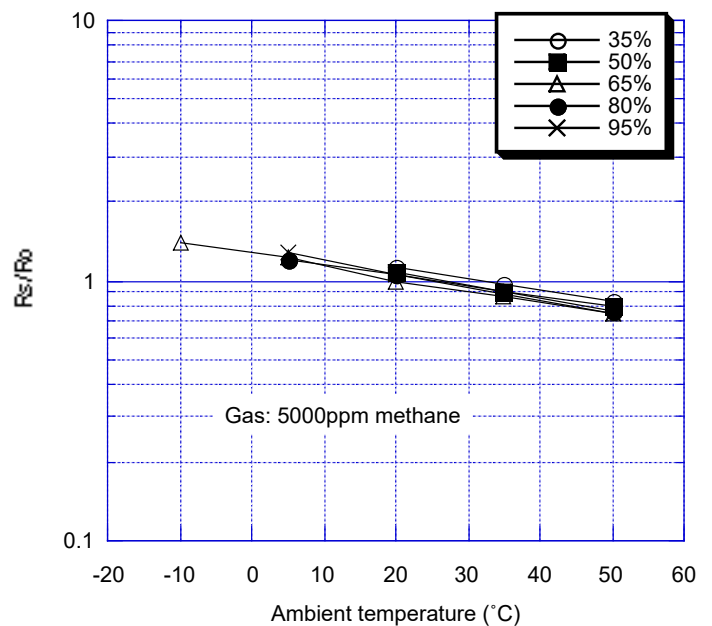

**IMPORTANT NOTE:** OPERATING CONDITIONS IN WHICH FIGARO SENSORS ARE USED WILL VARY WITH EACH CUSTOMER'S SPECIFIC APPLICATIONS. FIGARO STRONGLY RECOMMENDS CONSULTING OUR TECHNICAL STAFF BEFORE DEPLOYING FIGARO SENSORS IN YOUR APPLICATION AND, IN PARTICULAR, WHEN CUSTOMER'S TARGET GASES ARE NOT LISTED HEREIN. FIGARO CANNOT ASSUME ANY RESPONSIBILITY FOR ANY USE OF ITS SENSORS IN A PRODUCT OR APPLICATION FOR WHICH SENSOR HAS NOT BEEN SPECIFICALLY TESTED BY FIGARO.

### Basic Measuring Circuit:

The sensor requires two voltage inputs: heater voltage ( $V_H$ ) and circuit voltage ( $V_C$ ). The heater voltage ( $V_H$ ) is applied to the integrated heater in order to maintain the sensing element at a specific temperature which is optimal for sensing. Circuit voltage ( $V_C$ ) is applied to allow measurement of voltage  $V_{OUT}(V_{RL})$  across a load resistor ( $R_L$ ) which is connected in series with the sensor.

A common power supply circuit can be used for both  $V_C$  and  $V_H$  to fulfill the sensor's electrical requirements. The value of the load resistor ( $R_L$ ) should be chosen to optimize the alarm threshold value, keeping power dissipation ( $P_S$ ) of the semiconductor below a limit of 15mW. Power dissipation ( $P_S$ ) will be highest when the value of  $R_S$  is equal to  $R_L$  on exposure to gas.

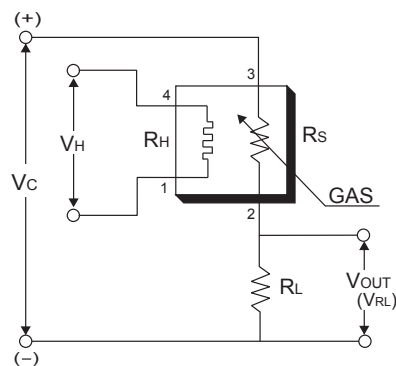

### Specifications:

Model number		TGS2611-E00	
Sensing principle		MOS type	
Standard package		TO-5 metal can	
Target gases		Methane, Natural Gas	
Typical detection range		1~25% LEL	
Standard circuit conditions	Heater voltage	$V_H$	5.0±0.2V AC/DC
	Circuit voltage	$V_C$	5.0±0.2V DC $P_S \leq 15mW$
	Load resistance	$R_L$	variable    0.45kΩ min.
Electrical characteristics under standard test conditions	Heater resistance	$R_H$	approx 59Ω at room temp.
	Heater current	$I_H$	56±5mA
	Heater power consumption	$P_H$	280mW±25mW
	Sensor resistance	$R_S$	0.83~8.30kΩ in 5000ppm methane
	Sensitivity (change ratio of $R_S$ )		0.52~0.65 in methane $\frac{R_S(9000ppm)}{R_S(3000ppm)}$
Standard test conditions	Test gas conditions	Methane in air at 20±2°C, 65±5%RH	
	Circuit conditions	$V_C = 5.0 \pm 0.01V$ DC $V_H = 5.0 \pm 0.05V$ DC	
	Preheating period before test	7 days	

### Structure and Dimensions:

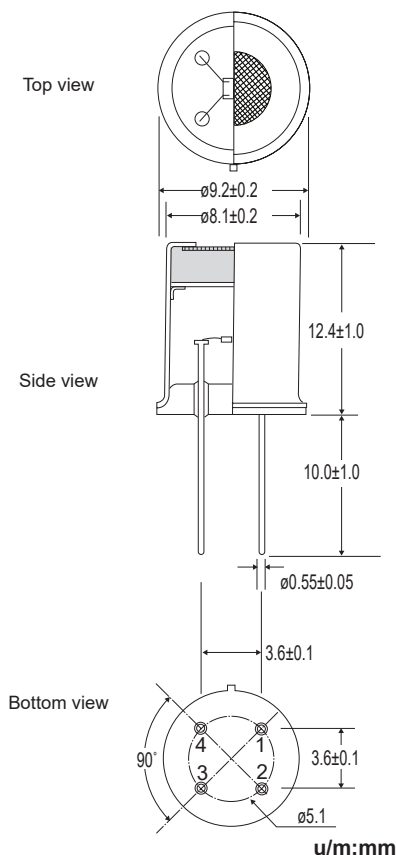

The value of power dissipation ( $P_S$ ) can be calculated by utilizing the following formula:

$$P_S = \frac{(V_C - V_{RL})^2}{R_S}$$

Sensor resistance ( $R_S$ ) is calculated with a measured value of  $V_{OUT}(V_{RL})$  by using the following formula:

$$R_S = \left( \frac{V_C}{V_{RL}} - 1 \right) \times R_L$$

#### Pin connection:

- 1: Heater
- 2: Sensor electrode (-)
- 3: Sensor electrode (+)
- 4: Heater

All sensor characteristics shown in this brochure represent typical characteristics. Actual characteristics vary from sensor to sensor. The only characteristics warranted are those in the Specification table above.

Before purchasing this product, please read the Warranty Statements shown in our webpage by scanning this QR code.



[https://www.figaro.co.jp/en/pdf/Limited\\_Warranty\\_en.pdf](https://www.figaro.co.jp/en/pdf/Limited_Warranty_en.pdf)

#### FIGARO ENGINEERING INC.

1-5-11 Senba-nishi  
Mino, Osaka 562-8505 JAPAN  
Phone: (81)-727-28-2045  
email: [figaro@figaro.co.jp](mailto:figaro@figaro.co.jp)  
[www.figaro.co.jp](http://www.figaro.co.jp)