

TGS 3830 - for the detection Chlorofluorocarbons (CFCs)

Features:

- * Low power consumption
- * High sensitivity to R-134a
- * Quick response to R-134a

Applications:

- * Portable refrigerant leak detector

TGS 3830 is Figaro's new metal oxide semiconductor gas sensor for the detection of Chlorofluorocarbons. The sensing element of the sensor is a tin dioxide (SnO₂) semiconductor which has low conductivity increases depending on the gas concentration in the air. A simple electrical circuit can convert the change in conductivity to an output signal which corresponds to the gas concentration. Miniaturization of the gas sensing bead results in a heater power consumption of only 120mW.

The TGS3830 has high sensitivity to R-134a, the most promising alternative to R-12, commonly used in air conditioning systems and refrigerators. With its quick response speed, TGS3830 is an excellent, low-cost sensor for portable refrigerant leak detector.



The figure below represents typical sensitivity characteristics, all data having been gathered at standard test conditions (see reverse side of this sheet). The Y-axis is indicated as sensor resistance ratio (Rs/Ro) which is defined as follows:

R_s = Sensor resistance in displayed gases at various concentrations
 R_o = Sensor resistance in fresh air

The figure below represents typical gas response and repeatability in flow conditions of 100cc/min.. The Y-axis is indicated as sensor resistance ratio (Rs/Ro) which is defined as follows:

R_s = Sensor resistance in displayed gases at various concentrations
 R_o = Sensor resistance in fresh air

Sensitivity Characteristics:

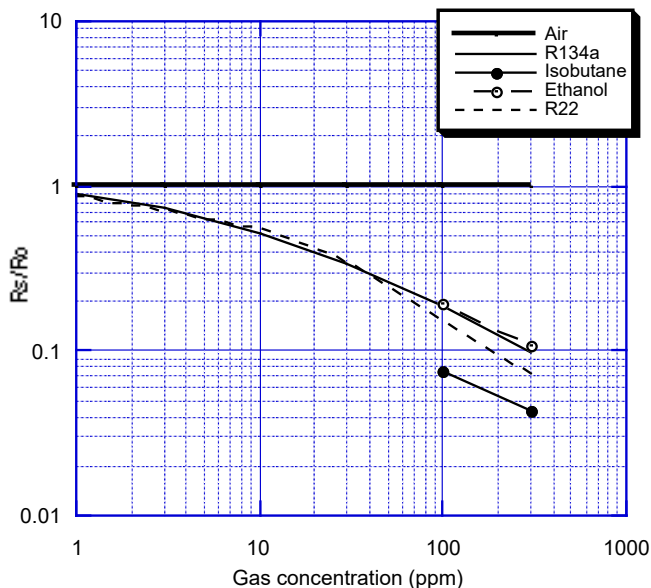

Gas Response and Repeatability:

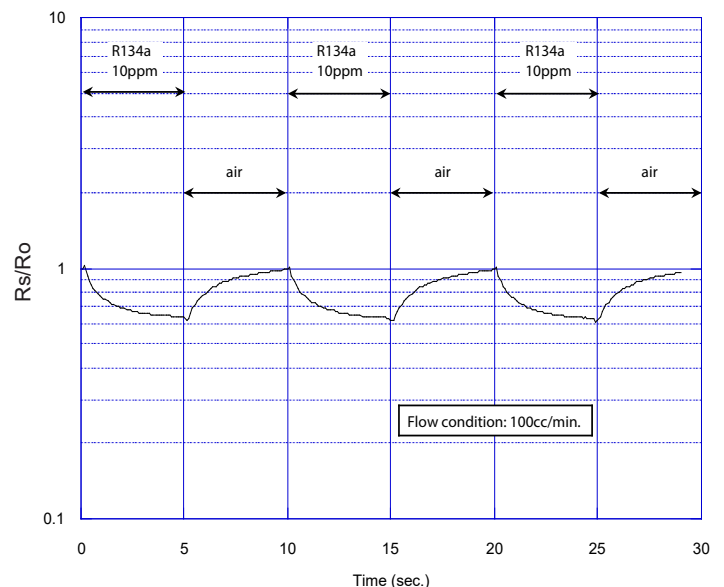

IMPORTANT NOTE: OPERATING CONDITIONS IN WHICH FIGARO SENSORS ARE USED WILL VARY WITH EACH CUSTOMER'S SPECIFIC APPLICATIONS. FIGARO STRONGLY RECOMMENDS CONSULTING OUR TECHNICAL STAFF BEFORE DEPLOYING FIGARO SENSORS IN YOUR APPLICATION AND, IN PARTICULAR, WHEN CUSTOMER'S TARGET GASES ARE NOT LISTED HEREIN. FIGARO CANNOT ASSUME ANY RESPONSIBILITY FOR ANY USE OF ITS SENSORS IN A PRODUCT OR APPLICATION FOR WHICH SENSOR HAS NOT BEEN SPECIFICALLY TESTED BY FIGARO.

Basic Measuring Circuit:

The sensor requires two voltage inputs: heater voltage (V_H) and circuit voltage (V_C). The sensor has three pins: Pin #3--heater (+), Pin #2--sensor electrode (+), and Pin #1--common (-). To maintain the sensing element at specific temperatures which are optimal for sensing two different gases, heater

voltage of 0.8V is applied continuously between pins #1 and #3.

Circuit voltage (V_C) is applied between both ends of the sensor (R_S) and a load resistor (R_L), which are connected in series, to allow measurement of voltage (V_{RS}).

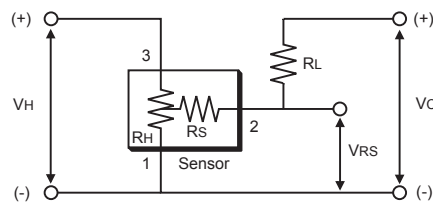

Basic measuring circuit

Specifications:

Model number		TGS3830	
Sensing element type		Micro-bead	
Standard package		Plastic base and metal can	
Target gases		R-134a	
Typical detection range		5~100ppm	
Standard circuit conditions	Heater voltage	V_H	$V_H = 0.8V \pm 3\%$
	Circuit voltage	V_C	5.0V DC max.
	Load resistance	R_L	variable (10k Ω min.)
Electrical characteristics under standard test conditions	Heater resistance	R_H	3.0 \pm 0.3 Ω at room temp.
	Heater power consumption	P_H	approx. 100mW
	Sensor resistance	R_S	10~640k Ω in air
	Sensitivity (change ratio of R_S)	≤ 0.85	$\frac{R_S (10ppm R134a)}{R_S (air)}$
Standard test conditions	Test gas conditions	Target gas in air at 20 \pm 2 $^{\circ}$ C, 65 \pm 5%RH	
	Circuit conditions	$V_H = 0.8V \pm 2\%$	
	Preheating period before test	1 hour	
Expected lifetime (total operating time)		2,000 hours in air	

NOTE: Sensor resistance (R_S) is calculated with a measured value of V_{RS} by using the following formula:

$$R_S = \frac{(V_{RS} - 0.5V_H)}{(V_C - V_{RS})} \times R_L$$

Structure and Dimensions:

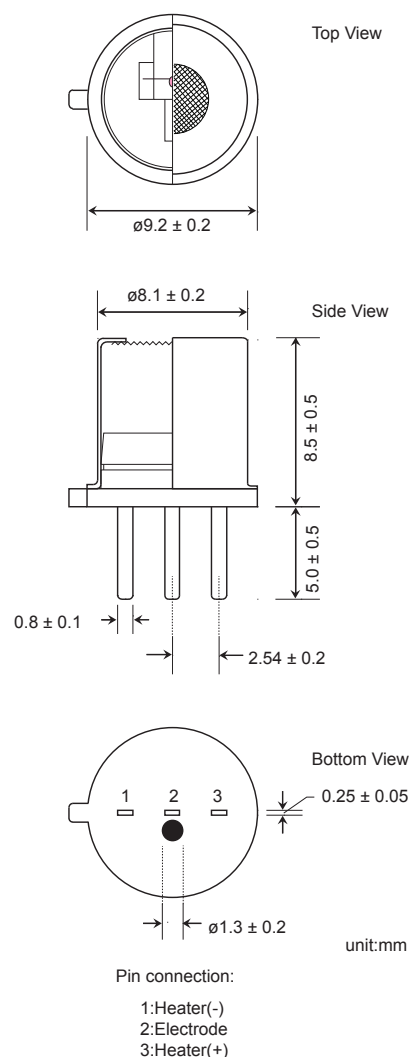

All sensor characteristics shown in this brochure represent typical characteristics. Actual characteristics vary from sensor to sensor. The only characteristics warranted are those in the Specification table above.

Before purchasing this product, please read the Warranty Statements shown in our webpage by scanning this QR code.



https://www.figaro.co.jp/en/pdf/Limited_Warranty_en.pdf

FIGARO ENGINEERING INC.

1-5-11 Senba-nishi
 Mino, Osaka 562-8505 JAPAN
 Phone: (81)-727-28-2045
 URL: www.figaro.co.jp/en/