

TGS5141-P00 - for the detection of Carbon Monoxide

Features:

- * Ultra compact
- * Battery operable
- * High repeatability/selectivity to CO
- * Linear relationship between CO gas concentration and sensor output
- * Simple calibration
- * Long life
- * UL recognized component
- * Meets UL2034, EN50291, and EN54-31 requirements

Applications:

- * Residential and commercial CO detectors
- * Fire detection
- * Safety measures for lithium-ion batteries

Figaro's **TGS5141** is a battery operable electrochemical sensor which uses a unique electrolyte that eliminates the need for a water reservoir. By eliminating the water reservoir used in TGS5042, the comparative size of TGS5141 is reduced to just 10% of TGS5042. With its ultra compact size, this sensor is the ideal choice for size oriented applications such as portable CO detectors, small residential CO detectors, and multi-sensor fire detectors. OEM customers will find individual sensors data printed on each sensor in bar code form, enabling users to skip the costly gas calibration process and allowing for individual sensor tracking.



The figure below represents typical sensitivity characteristics, all data having been gathered at standard test conditions (see reverse side of this sheet). The Y-axis shows the output current of the sensor ($I_{out}/\mu A$) in each gas. Output current is linear to CO concentration, with a deviation of less than $\pm 5\%$ in the range of 0~1000ppm.

The figure below represents typical temperature dependency characteristics. The Y-axis shows the sensor output ratio (I/I_0) as defined below. The linear relationship between I/I_0 and CO concentration is constant regardless of the CO concentration range.

I = Sensor output current in 400ppm of CO at various temperatures

I_0 = Sensor output current in 400ppm at 20°C/50%RH

Sensitivity Characteristics:

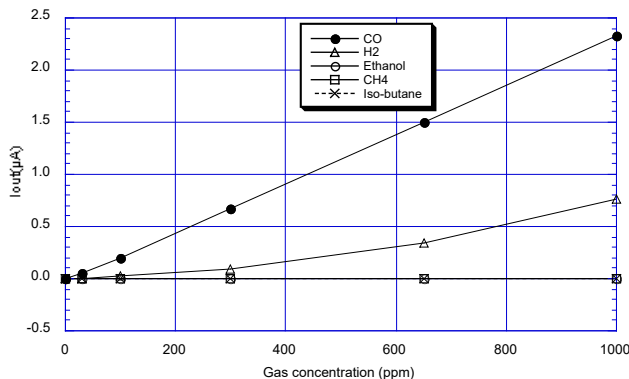

Temperature Dependency:

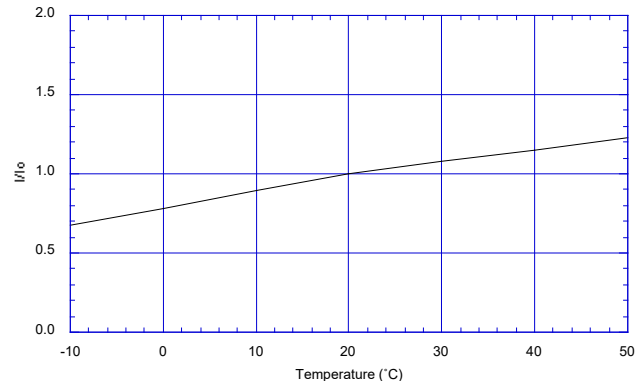

IMPORTANT NOTE: OPERATING CONDITIONS IN WHICH FIGARO SENSORS ARE USED WILL VARY WITH EACH CUSTOMER'S SPECIFIC APPLICATIONS. FIGARO STRONGLY RECOMMENDS CONSULTING OUR TECHNICAL STAFF BEFORE DEPLOYING FIGARO SENSORS IN YOUR APPLICATION AND, IN PARTICULAR, WHEN CUSTOMER'S TARGET GASES ARE NOT LISTED HEREIN. FIGARO CANNOT ASSUME ANY RESPONSIBILITY FOR ANY USE OF ITS SENSORS IN A PRODUCT OR APPLICATION FOR WHICH SENSOR HAS NOT BEEN SPECIFICALLY TESTED BY FIGARO.

Basic Measuring Circuit:

The diagram at the right shows the basic measuring circuit of TGS5141. The sensor generates a minute electric current which is converted into sensor output voltage (V_{out}) by an op-amp/resistor ($R1$) combination.

Figaro recommends the following electrical parts:

$R1$: $1M\Omega$

$C1$: $1\mu F$

IC : NL2333 (Nisshinbo Micro Devices Inc.)

NOTE: When voltage is applied to the sensor output terminal, the sensor may be damaged. Voltage applied to the sensor should be strictly limited to less than $\pm 10mV$. An additional resistor or FET is required to prevent polarization of the sensor when V_c is off.

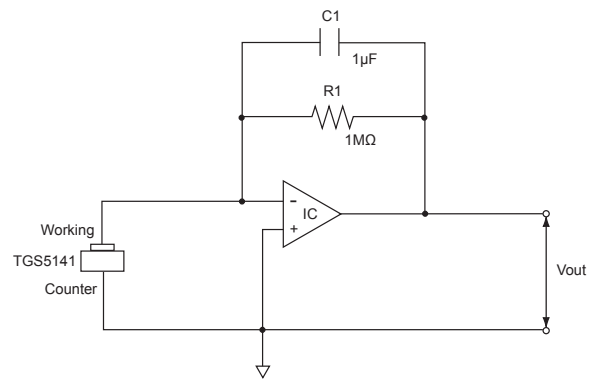

Basic measuring circuit of TGS5141

Specifications:

Item	Specification
Model number	TGS5141-P00
Target gases	Carbon monoxide
Typical detection range	0 ~ 5,000ppm
Output current in CO	1.2~3.2nA/ppm
Baseline offset(*1)	< ± 10 ppm equivalent
Operating temperature	-10°C ~ +50°C (continuous) -20°C ~ +60°C (intermittent)
Operating humidity	10 ~ 95%RH (no condensation)
Response time (T90)	within 60 seconds
Storage conditions	-10°C ~ +50°C (continuous) -20°C ~ +60°C (intermittent)
Weight	approx. 2.5g
Standard test conditions	20 \pm 2°C, 40 \pm 10%RH

(*1) Represents sensor output in air under operating conditions

Structure and Dimensions:

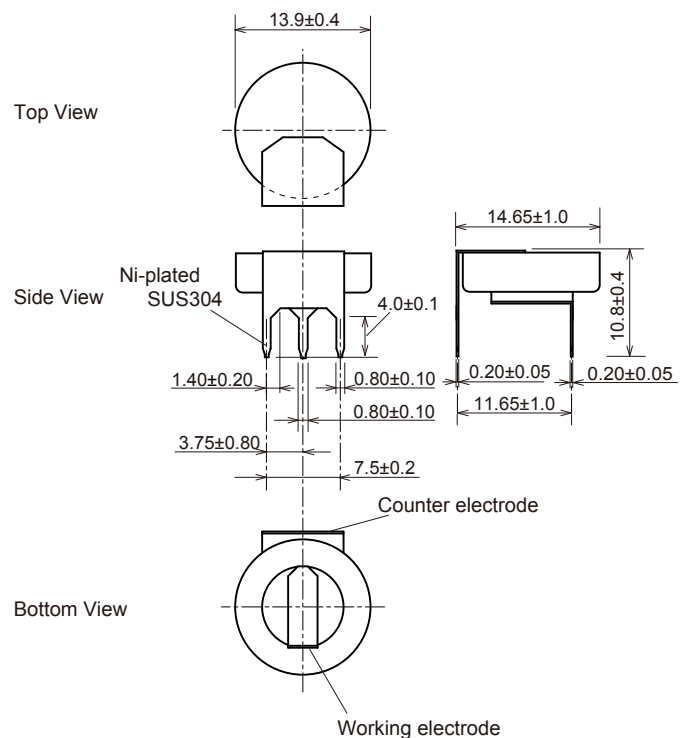

Unit : mm

All sensor characteristics shown in this brochure represent typical characteristics. Actual characteristics vary from sensor to sensor. The only characteristics warranted are those in the Specification table above.

Before purchasing this product, please read the Warranty Statements shown in our webpage by scanning this QR code.



https://www.figaro.co.jp/en/pdf/Limited_Warranty_en.pdf

FIGARO ENGINEERING INC.
1-5-11 Senba-nishi
Mino, Osaka 562-8505 JAPAN
Phone: (81)-727-28-2045
URL: www.figaro.co.jp/en/